

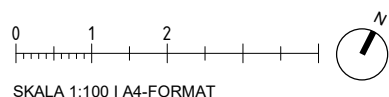

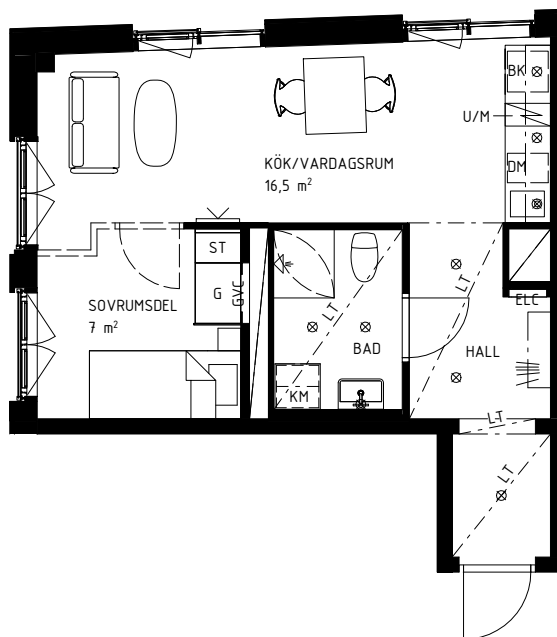

















LÄGENHETSNUMMER

3:1101



FÖRKLARINGAR

	GARDEROB		HATTHYLLA		FRANSK BALKONG
	STÄDSKÅP		GOLVVÄRMECENTRAL		VIKBARA DUSCHVÄGGAR AV GLAS
	INTEGRERAD BÄNKKYL		ELCENTRAL/MEDIASKÅP		SCHAKT
	KOMBIMASKIN TVÄTT/TORK		PLATS FÖR TV	RUMSHÖJD CA 2,50 m, OM INGET ANNAT ANGES.	
	BÄNKSKIVA MED ÖVERSKÅP		INFÄLLD SPOTLIGHT	FÖNSTER ÄR GLASADE NER TILL GOLV OM INGEN BRÖSTNINGS-HÖJD ANGES.	
	SPISHÅLL		SPEGELBELYSNING PÅ VÄGG		
	KOMBINERAD UGN & MIKROVÅGSUGN		LÄGRE TAKHÖJD		
	DISKMASKIN		MÖJLIG RUMSINDELNING		
	DISKHO				

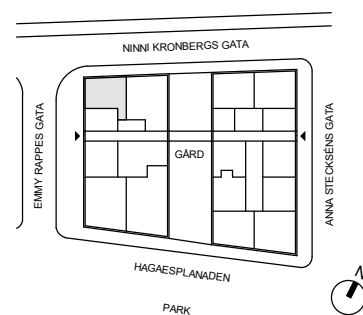
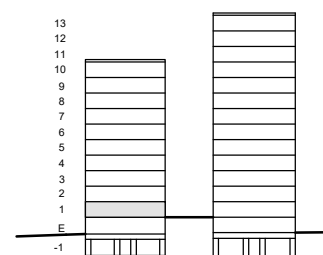

LÄGENHETSNUMMER

3:1102

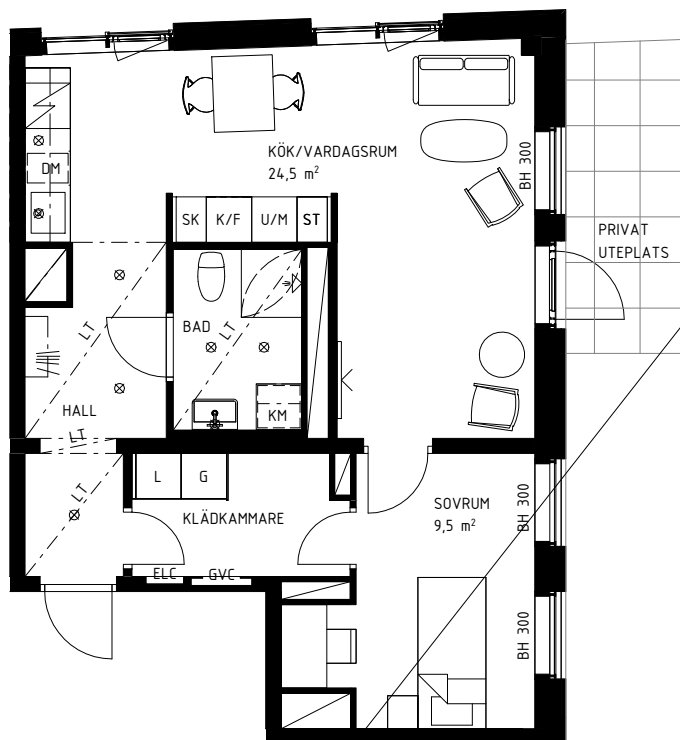

SENARE FÖRSÄLJNINGSETAPP

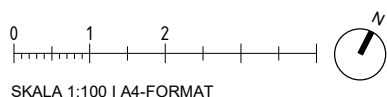

FÖRKLARINGAR

SK	SKAFFERI		DISKHO		FRANSK BALKONG
ST	STÄD		HATTHYLLA		VIKBARA DUSCHVÄGGAR AV GLAS
K/F	KYL/FRYS	GVC	GOLVVÄRMECENTRAL		SCHAKT
G	GARDEROB	ELC	ELCENTRAL/MEDIASKÅP		
L	LINNESKÅP		PLATS FÖR TV		
KM	KOMBIMASKIN TVÄTT/TORK		INFÄLLD SPOTLIGHT		RUMSHÖJD CA 2,50 m, OM INGET ANNAT ANGES.
	BÄNKSKIVA MED ÖVERSKÅP		SPEGELBELYSNING PÅ VÄGG		FÖNSTER ÄR GLASADE NER TILL GOLV OM INGEN BRÖSTNINGSHÖJD ANGES.
	SPISHÄLL	BH	BRÖSTNINGSHÖJD		
U/M	UGN & MIKROVÅGSUGN	LT	LÄGRE TAKHÖJD		
DM	DISKMASKIN				

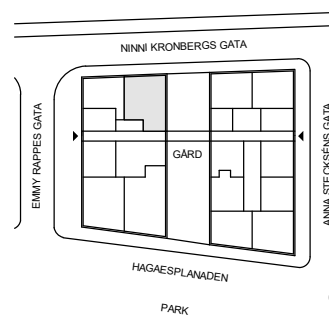
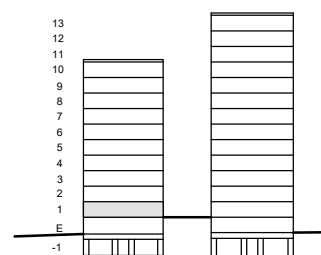





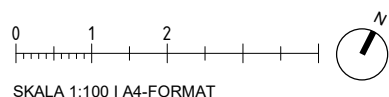
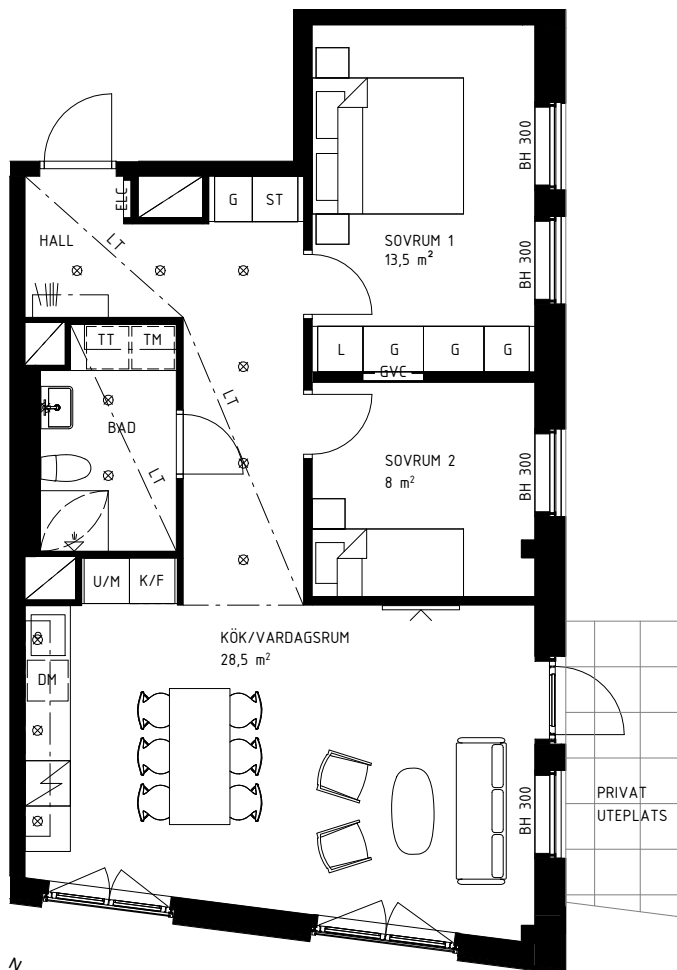

















LÄGENHETSNUMMER

3:1103



SKALA 1:100 | A4-FORMAT

FÖRKLARINGAR

	GARDEROB		DISKHO		FRANSK BALKONG
	STÄDSKÅP		HATTHYLLA		VIKBARA DUSCHVÄGGAR AV GLAS
	LINNESKÅP		GOLVVÄRMECENTRAL		SCHAKT
	KYL/FRYS		ELCENTRAL/MEDIASKÅP		PLATS FÖR TV
	TVÄTTMASKIN		INFÄLLD SPOTLIGHT	RUMSHÖJD CA 2,50 m, OM INGET ANNAT ANGES.	
	TORKTUMLARE		SPEGELBELYSNING PÅ VÄGG	FÖNSTER ÄR GLASADE NER TILL GOLV OM INGEN BRÖSTNINGS-HÖJD ANGES.	
	BÄNKSKIVA MED ÖVERSKÅP		BRÖSTNINGSHÖJD		
	SPISHÄLL		LÄGRE TAKHÖJD		
	UGN & MIKROVÅGSUGN				
	DISKMASKIN				

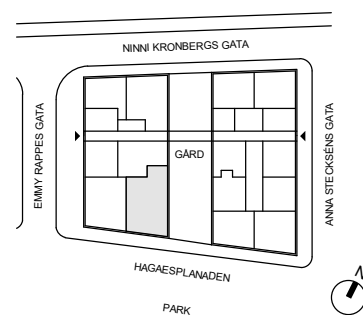
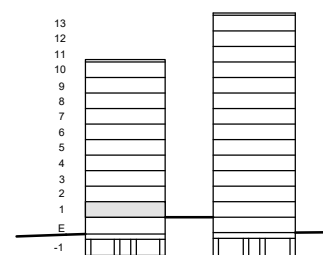





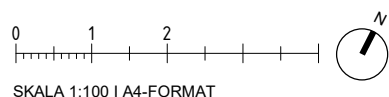
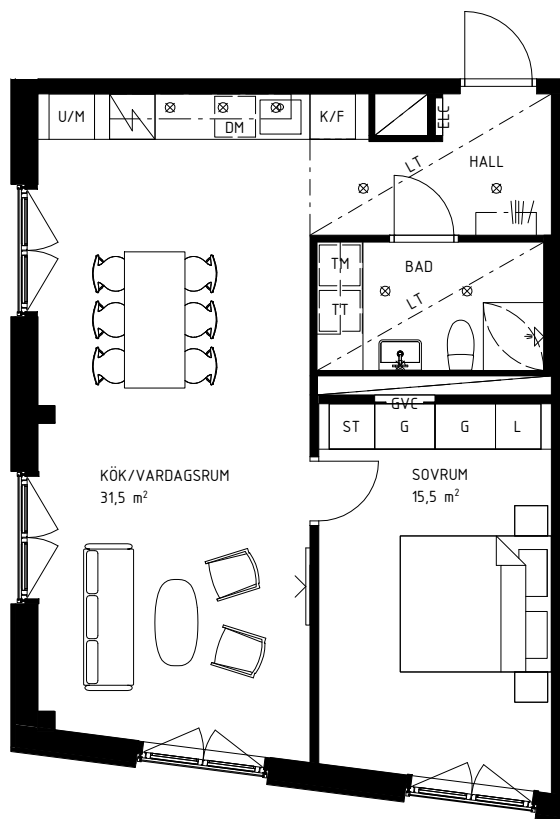















LÄGENHETSNUMMER

3:1104



SKALA 1:100 | A4-FORMAT

FÖRKLARINGAR

 G	GARDEROB	 DM	DISKMASKIN		FRANSK BALKONG
 L	LINNESKÅP		DISKHO		VIKBARA DUSCHVÄGGAR AV GLAS
 ST	STÄDSKÅP		HATTHYLLA		SCHAKT
 K/F	KYL/FRYS		GOLVVÄRMECENTRAL		
 TM	TVÄTTMASKIN		ELCENTRAL/MEDIASKÅP		
 TT	TORKTUMLARE		PLATS FÖR TV		
	BÄNKSIVA MED ÖVERSKÅP		INFÄLLD SPOTLIGHT		
	SPISHÄLL		SPEGELBELYSNING PÅ VÄGG		
 U/M	UGN & MIKROVÅGSUGN		LÄGRE TAKHÖJD		

RUMSHÖJD CA 2,50 m, OM INGET
ANNAT ANGES.

FÖNSTER ÄR GLASADE NER TILL GOLV
OM INGEN BRÖSTNINGS-HÖJD ANGES.

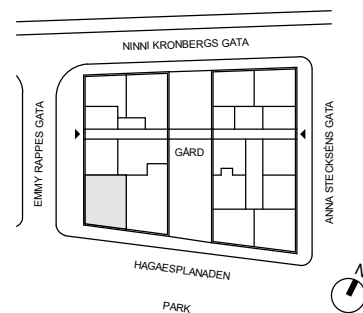
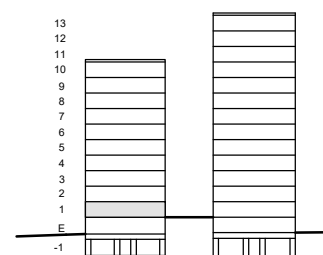





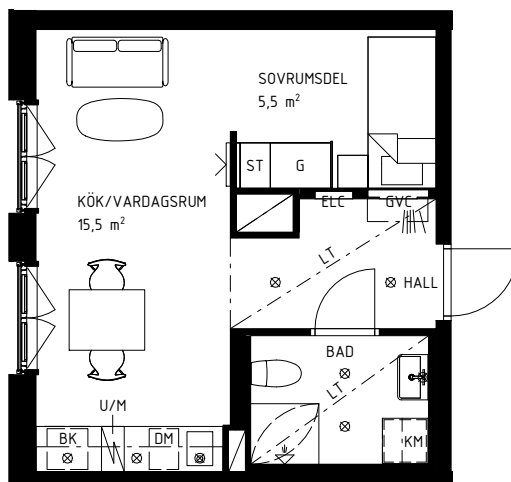













LÄGENHETSNUMMER

3:1105



FÖRKLARINGAR

	GARDEROB		DISKHO		FRANSK BALKONG
	STÄDSKÅP		HATTHYLLA		VIKBARA DUSCHVÄGGAR AV GLAS
	INTEGRERAD BÄNKKYL		GOLVVÄRMECENTRAL		SCHAKT
	KOMBIMASKIN TVÅTT/TORK		ELCENTRAL/MEDIASKÅP		
	BÄNKSKIVA MED ÖVERSKÅP		PLATS FÖR TV		
	SPISHÄLL		INFÄLLD SPOTLIGHT		
	KOMBINERAD UGN & MIKROVÅGSUGN		SPEGELBELYSNING PÅ VÄGG		
	DISKMASKIN		LÄGRE TAKHÖJD		

RUMSHÖJD CA 2,50 m, OM INGET ANNAT ANGES.
FÖNSTER ÄR GLASADE NER TILL GOLV OM INGEN BRÖSTNINGSHÖJD ANGES.

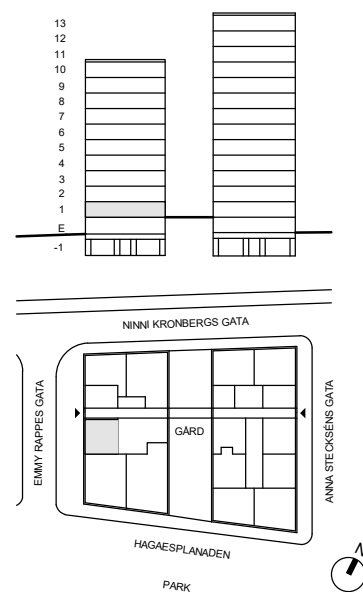





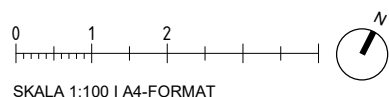
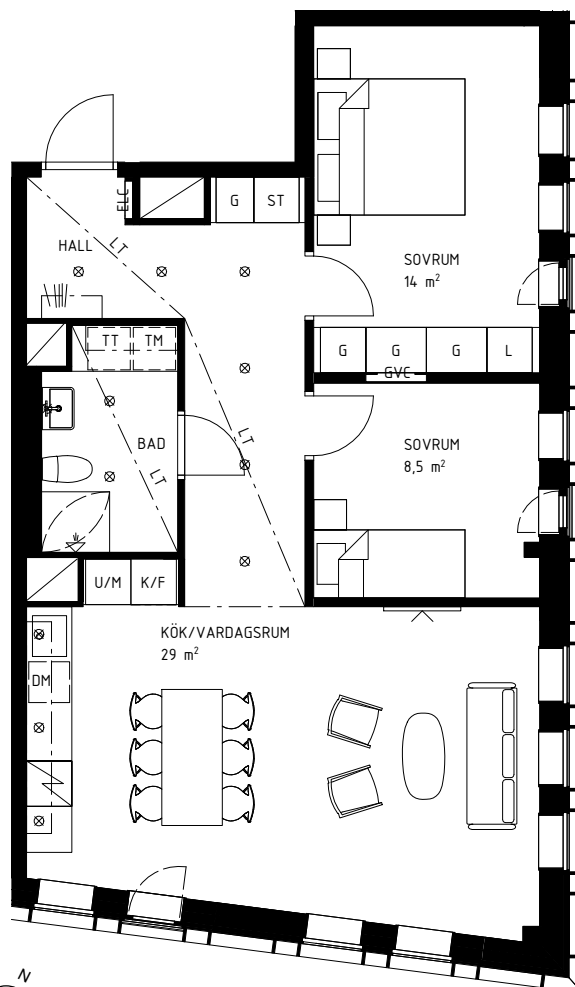















LÄGENHETSNUMMER

3:1201
3:1301
3:1401
3:1501
3:1601
3:1701
3:1801
3:1901



SKALA 1:100 | A4-FORMAT

FÖRKLARINGAR

 G	GARDEROB	 DM	DISKMASKIN		FRANSK BALKONG
 L	LINNESKÅP		DISKHO		VIKBARA DUSCHVÄGGAR AV GLAS
 ST	STÄDSKÅP		HATTHYLLA		SCHAKT
 K/F	KYL/FRYS		GOLVVÄRMECENTRAL		
 TM	TVÄTTMASKIN		ELCENTRAL/MEDIASKÅP		
 TT	TORKTUMLARE		PLATS FÖR TV		RUMSHÖJD CA 2,50 m, OM INGET ANNAT ANGES.
	BÄNKSKIVA MED ÖVERSKÅP		INFÄLLD SPOTLIGHT		FÖNSTER ÄR GLASADE NER TILL GOLV OM INGEN BRÖSTNINGS-HÖJD ANGES.
	SPISHÄLL		SPEGELBELYSNING PÅ VÄGG		
 U/M	UGN & MIKROVÅGSUGN		LÄGRE TAKHÖJD		

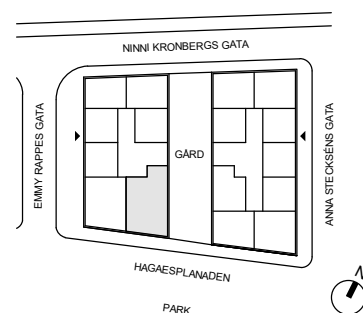
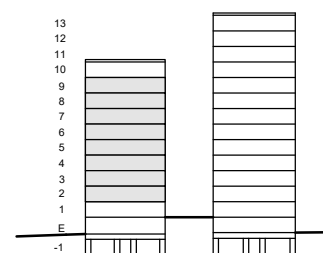

LÄGENHETSNUMMER

3:1202
3:1302
3:1402
3:1502
3:1602
3:1702
3:1802
3:1902

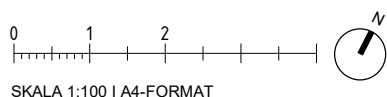
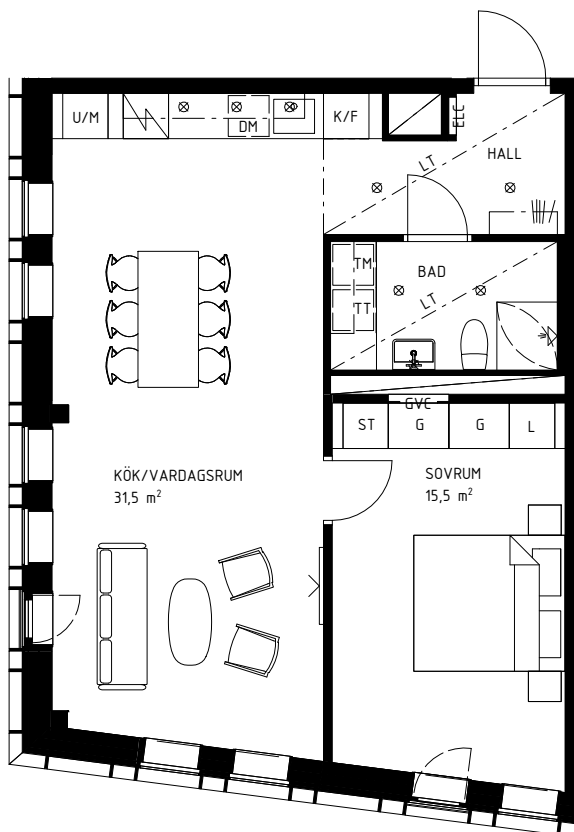

SKALA 1:100 | A4-FORMAT

FÖRKLARINGAR

G	GARDEROB	DM	DISKMASKIN		FRANSK BALKONG
L	LINNESKÅP		DISKHO		VIKBARA DUSCHVÄGGAR AV GLAS
ST	STÄDSKÅP		HATTHYLLA		SCHAKT
K/F	KYL/FRYS	GVC	GOLVVÄRMECENTRAL		
TM	TVÄTTMASKIN	ELC	ELCENTRAL/MEDIASKÅP		
TT	TORKTUMLARE		PLATS FÖR TV		
	BÄNKSKIVA MED ÖVERSKÅP		INFÄLLD SPOTLIGHT		
	SPISHÄLL		SPEGELBELYSNING PÅ VÄGG		
U/M	UGN & MIKROVÅGSUGN	LT	LÄGRE TAKHÖJD		

RUMSHÖJD CA 2,50 m, OM INGET ANNAT ANGES.
FÖNSTER ÄR GLASADE NER TILL GOLV OM INGEN BRÖSTNINGS-HÖJD ANGES.

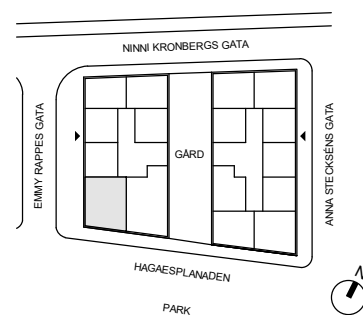
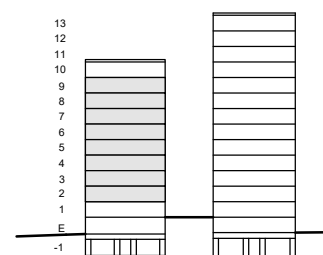





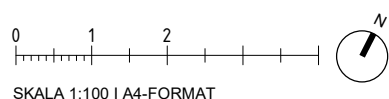
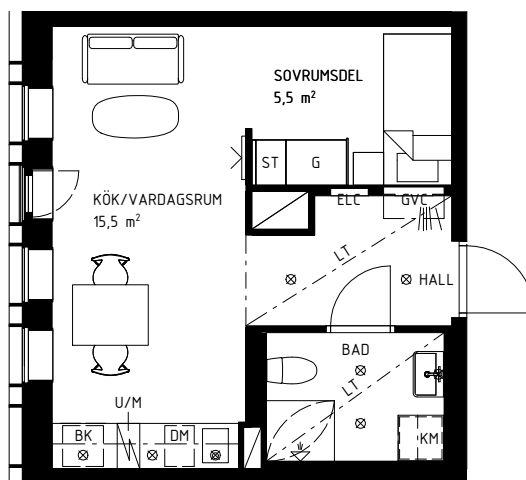













LÄGENHETSNUMMER

3:1203
3:1303
3:1403
3:1503
3:1603



SKALA 1:100 | A4-FORMAT

FÖRKLARINGAR

	GARDEROB		DISKHO		FRANSK BALKONG
	STÄDSKÅP		HATTHYLLA		VIKBARA DUSCHVÄGGAR AV GLAS
	INTEGRERAD BÄNKKYL		GOLVVÄRMECENTRAL		SCHAKT
	KOMBIMASKIN TVÄTT/TORK		ELCENTRAL/MEDIASKÅP		
	BÄNKSKIVA MED ÖVERSKÅP		PLATS FÖR TV		
	SPISHÄLL		INFÄLLD SPOTLIGHT		
	KOMBINERAD UGN & MIKROVÅGSUGN		SPEGELBELYSNING PÅ VÄGG		
	DISKMASKIN		LÄGRE TAKHÖJD		

RUMSHÖJD CA 2,50 m, OM INGET ANNAT ANGES.

FÖNSTER ÅR GLASADE NER TILL GOLV OM INGEN BRÖSTNINGS-HÖJD ANGES.

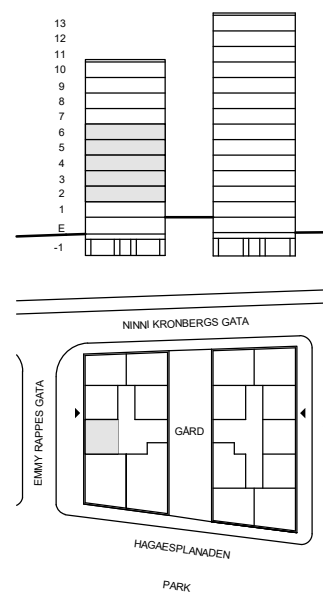

LÄGENHETSNUMMER

3:1204
3:1304
3:1404
3:1504
3:1604

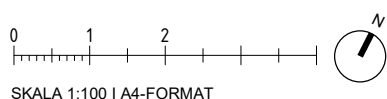
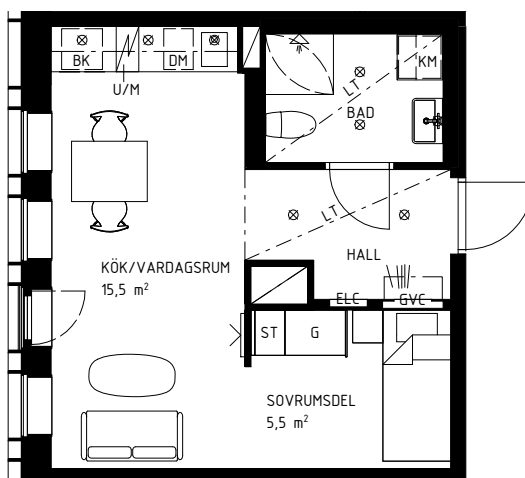

FÖRKLARINGAR

	GARDEROB		DISKHO		FRANSK BALKONG
	STÄDSKÅP		HATTHYLLA		VIKBARA DUSCHVÄGGAR AV GLAS
	INTEGRERAD BÄNKKYL		GOLVVÄRMECENTRAL		SCHAKT
	KOMBIMASKIN TVÄTT/TORK		ELCENTRAL/MEDIASKÅP		
	BÄNKSKIVA MED ÖVERSKÅP		PLATS FÖR TV		
	SPISHÄLL		INFÄLLD SPOTLIGHT		
	KOMBINERAD UGN & MIKROVÅGSUGN		SPEGELBELYSNING PÅ VÄGG		RUMSHÖJD CA 2,50 m, OM INGET ANNAT ANGES.
	DISKMASKIN		LÄGRE TAKHÖJD		FÖNSTER ÄR GLASADE NER TILL GOLV OM INGEN BRÖSTNINGS-HÖJD ANGES.

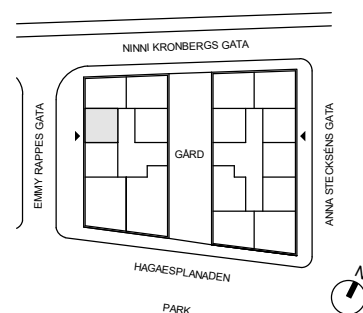
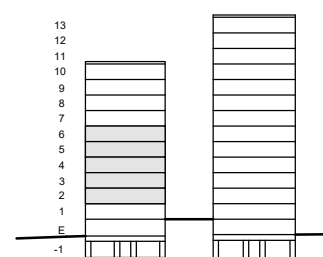





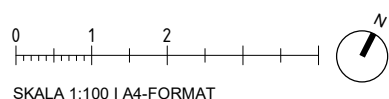
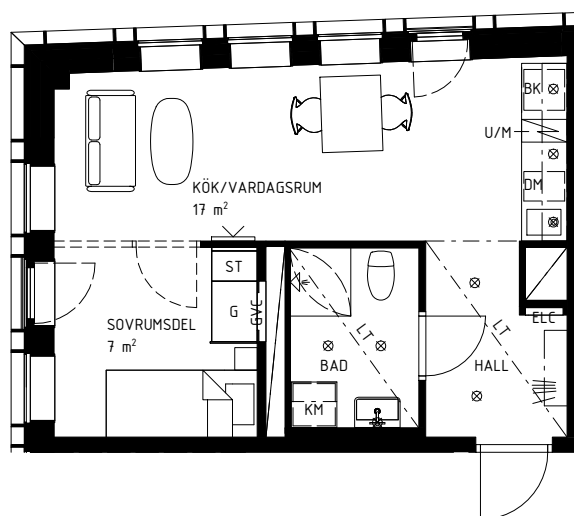















LÄGENHETSNUMMER

3:1205
3:1305
3:1405
3:1505
3:1605



FÖRKLARINGAR

	GARDEROB		HATTHYLLA		FRANSK BALKONG
	STÄDSKÅP		GOLVVÄRMECENTRAL		VIKBARA DUSCHVÄGGAR AV GLAS
	INTEGRERAD BÄNKKYL		ELCENTRAL/MEDIASKÅP		SCHAKT
	KOMBIMASKIN TVÄTT/TORK		PLATS FÖR TV		
	BÄNKSKIVA MED ÖVERSKÅP		INFÄLLD SPOTLIGHT		
	SPISHÄLL		SPEGELBELYSNING PÅ VÄGG		
	KOMBINERAD UGN & MIKROVÅGSUGN		LÄGRE TAKHÖJD		
	DISKMASKIN		MÖJLIG RUMSINDELNING		
	DISKHO				

RUMSHÖJD CA 2,50 m, OM INGET ANNAT ANGES.
FÖNSTER ÄR GLASADE NER TILL GOLV OM INGEN BRÖSTNINGS-HÖJD ANGES.

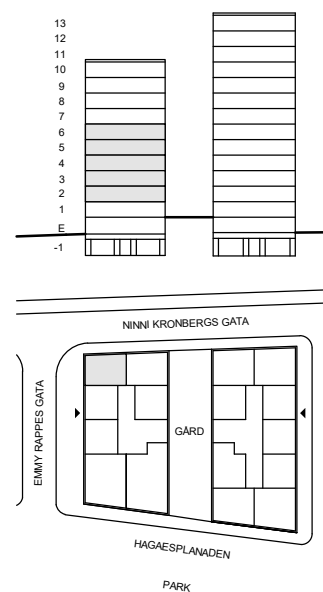





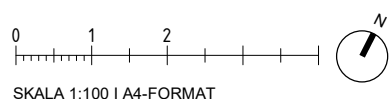
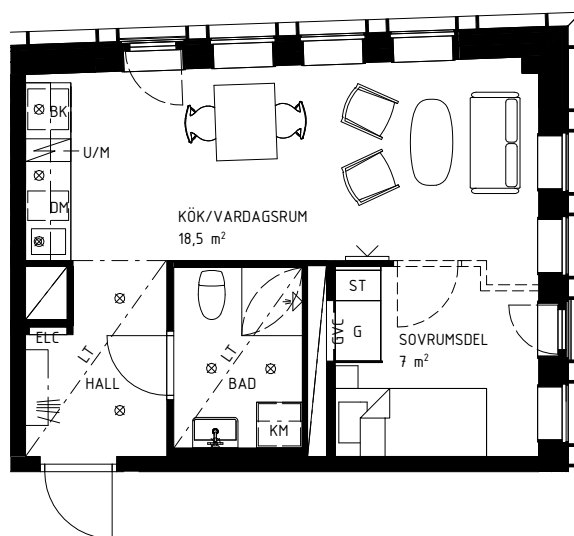















LÄGENHETSNUMMER

3:1206
3:1306
3:1406
3:1506
3:1606



SKALA 1:100 | A4-FORMAT

FÖRKLARINGAR

	GARDEROB		HATTHYLLA		FRANSK BALKONG
	STÄDSKÅP		GOLVVÄRMECENTRAL		VIKBARA DUSCHVÄGGAR AV GLAS
	INTEGRERAD BÄNKKYL		ELCENTRAL/MEDIASKÅP		SCHAKT
	KOMBIMASKIN TVÄTT/TORK		PLATS FÖR TV	RUMSHÖJD CA 2,50 m, OM INGET ANNAT ANGES. FÖNSTER ÄR GLASADE NER TILL GOLV OM INGEN BRÖSTNINGS-HÖJD ANGES.	
	BÄNKSKIVA MED ÖVERSKÅP		INFÄLLD SPOTLIGHT		
	SPISHÄLL		SPEGELBELYSNING PÅ VÄGG		
	KOMBINERAD UGN & MIKROVÅGSUGN		LÄGRE TAKHÖJD		
	DISKMASKIN		MÖJLIG RUMSINDELNING		
	DISKHO				

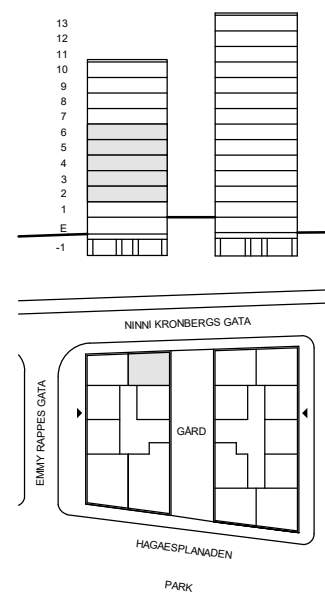

LÄGENHETSNUMMER

3:1207
3:1307
3:1407
3:1507
3:1607

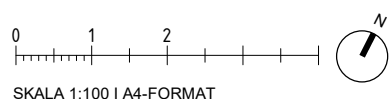
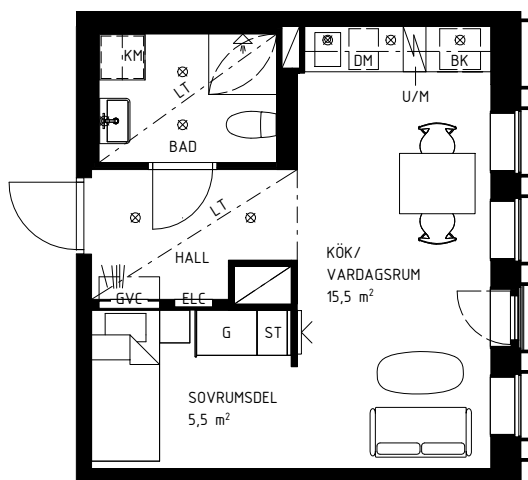

FÖRKLARINGAR

	GARDEROB		DISKHO		FRANSK BALKONG
	STÄDSKÅP		HATTHYLLA		VIKBARA DUSCHVÄGGAR AV GLAS
	INTEGRERAD BÄNKKYL		GOLVVÄRMECENTRAL		SCHAKT
	KOMBIMASKIN TVÄTT/TORK		ELCENTRAL/MEDIASKÅP		
	BÄNKSKIVA MED ÖVERSKÅP		PLATS FÖR TV		
	SPISHÄLL		INFÄLLD SPOTLIGHT		
	KOMBINERAD UGN & MIKROVÅGSUGN		SPEGELBELYSNING PÅ VÄGG		RUMSHÖJD CA 2,50 m, OM INGET ANNAT ANGES.
	DISKMASKIN		LÄGRE TAKHÖJD		FÖNSTER ÄR GLASADE NER TILL GOLV OM INGEN BRÖSTNINGS-HÖJD ANGES.

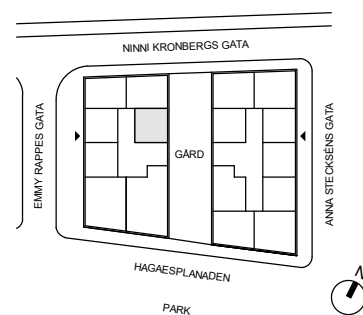
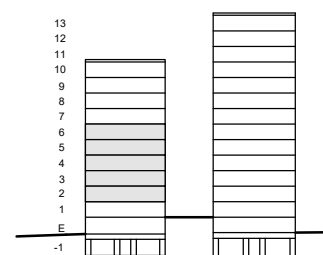





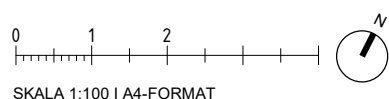
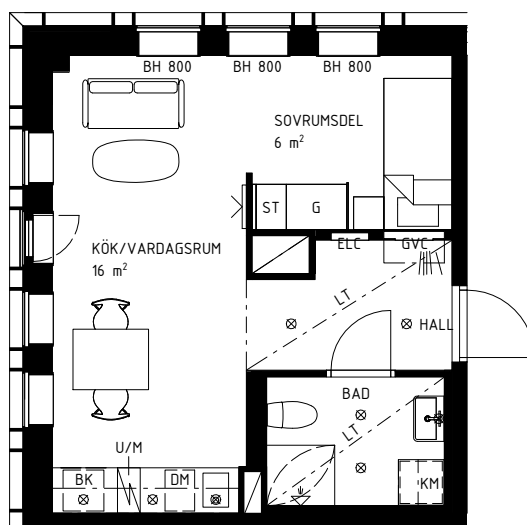















LÄGENHETSNUMMER

3:1703



SKALA 1:100 | A4-FORMAT

FÖRKLARINGAR

	GARDEROB		HATTHYLLA		FRANSK BALKONG
	STÄDSKÅP		GOLVVÄRMECENTRAL		VIKBARA DUSCHVÄGGAR AV GLAS
	INTEGRERAD BÄNKKYL		ELCENTRAL/MEDIASKÅP		SCHAKT
	KOMBIMASKIN TVÅTT/TORK		PLATS FÖR TV		
	BÄNKSKIVA MED ÖVERSKÅP		INFÄLLD SPOTLIGHT		
	SPISHÄLL		SPEGELBELYSNING PÅ VÄGG		
	KOMBINERAD UGN & MIKROVÅGSUGN		BRÖSTNINGSHÖJD		RUMSHÖJD CA 2,50 m, OM INGET ANNAT ANGES.
	DISKMASKIN		LÄGRE TAKHÖJD		FÖNSTER ÄR GLASADE NER TILL GOLV OM INGEN BRÖSTNINGSHÖJD ANGES.
	DISKHO				

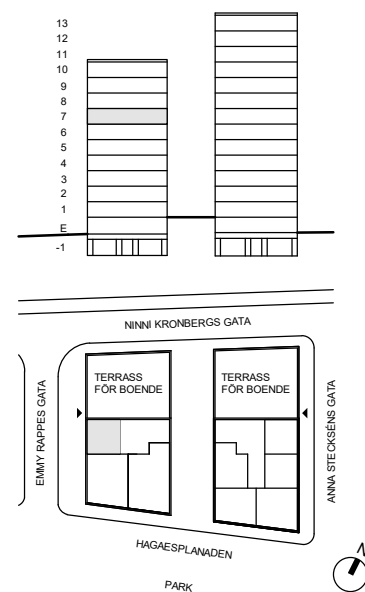

LÄGENHETSNUMMER





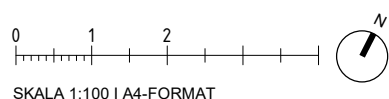
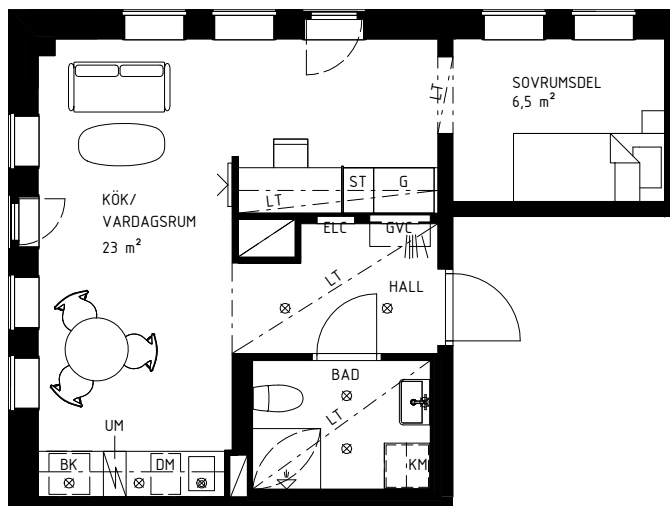













3:1803

3:1903



SKALA 1:100 | A4-FORMAT

FÖRKLARINGAR

	GARDEROB		DISKHO		FRANSK BALKONG
	STÄDSKÅP		HATTHYLLA		VIKBARA DUSCHVÄGGAR AV GLAS
	INTEGRERAD BÄNKKYL		GOLVVÄRMECENTRAL		SCHAKT
	KOMBIMASKIN TVÄTT/TORK		ELCENTRAL/MEDIASKÅP		
	BÄNKSKIVA MED ÖVERSKÅP		PLATS FÖR TV		
	SPISHÅLL		INFÄLLD SPOTLIGHT		
	KOMBINERAD UGN & MIKROVÅGSUGN		SPEGELBELYSNING PÅ VÄGG		
	DISKMASKIN		LÄGRE TAKHÖJD		

RUMSHÖJD CA 2,50 m, OM INGET ANNAT ANGES.

FÖNSTER ÅR GLASADE NER TILL GOLV OM INGEN BRÖSTNINGS-HÖJD ANGES.

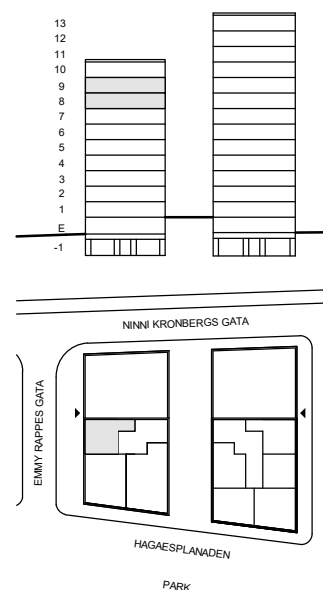





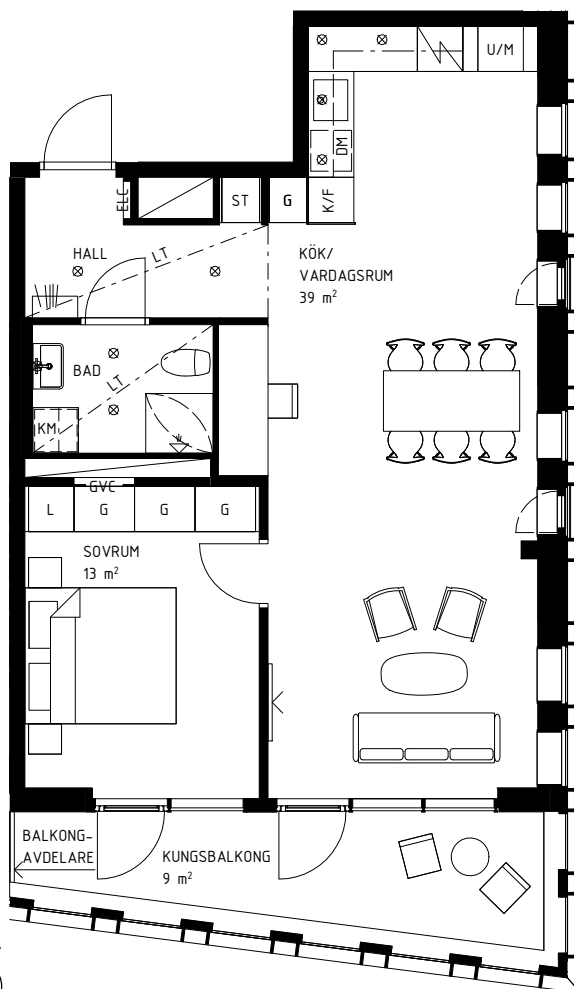















LÄGENHETSNUMMER

3:2001



SKALA 1:100 | A4-FORMAT

FÖRKLARINGAR

 G	GARDEROB	 DISKHO	 FRANSK BALKONG
 L	LINNESKÅP	 HATTHYLLA	 VIKBARA DUSCHVÄGGAR AV GLAS
 ST	STÄDSKÅP	 GVC	 SCHAKT
 K/F	KYL/FRYS	 ELC	ELCENTRAL/MEDIASKÅP
 KM	KOMBIMASKIN TVÄTT/TORK	 PLATS FÖR TV	RUMSHÖJD CA 2,50 m, OM INGET ANNAT ANGES.
 BÄNKSKIVA MED ÖVERSKÅP		 INFÄLLD SPOTLIGHT	FÖNSTER ÄR GLASADE NER TILL GOLV OM INGEN BRÖSTNINGSHÖJD ANGES.
 SPISHÄLL		 SPEGELBELYSNING PÅ VÄGG	
 U/M	UGN & MIKROVÅGSUGN	 LT	LÄGRE TAKHÖJD
 DM	DISKMASKIN		

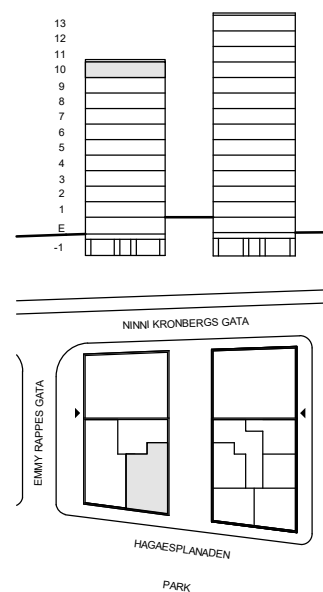

LÄGENHETSNUMMER

3:2002

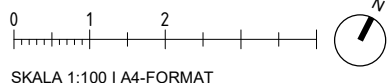
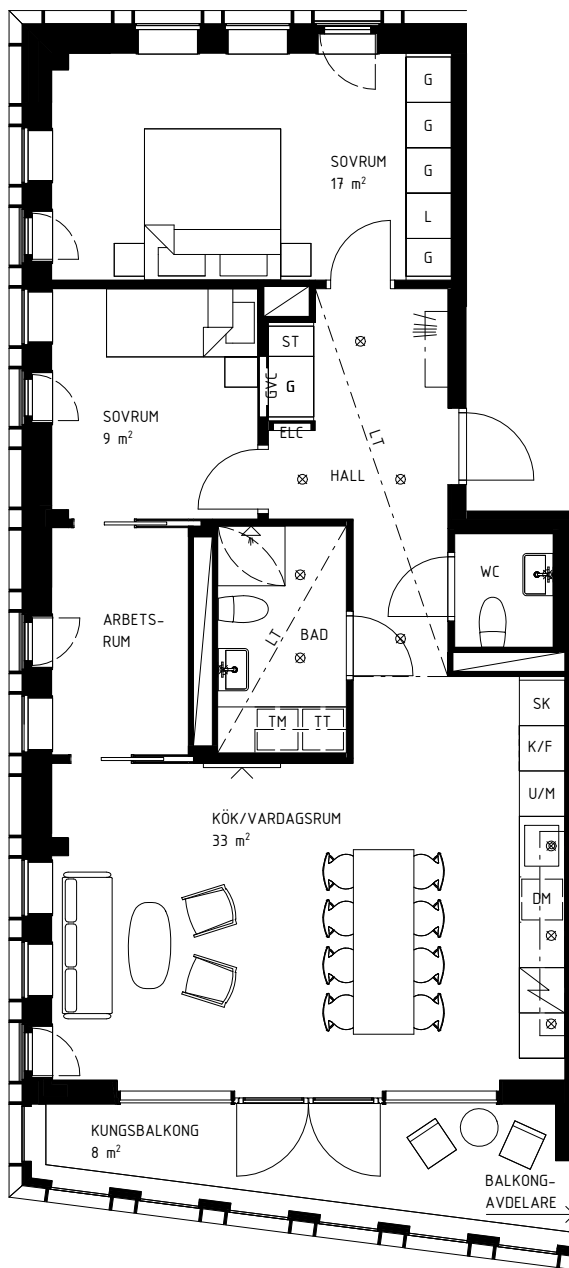

SKALA 1:100 | A4-FORMAT

FÖRKLARINGAR

- | | | | | | |
|-----|------------------------|--------------|-------------------------|-----------------------------|---------------|
| G | GARDEROB | U/M | UGN & MIKROVÅGSUGN | FRANSK BALKONG | |
| L | LINNESKÅP | HATTHYLLA | | VIKBARA DUSCHVÄGGAR AV GLAS | |
| ST | STÅDSKÅP | DM | DISKMASKIN | LT | LÄGRE TAKHÖJD |
| SK | SKAFFERI | DISKHO | | SCHAKT | |
| K/F | KYL/FRYS | GVC | GOLVVÄRMECENTRAL | | |
| TM | TVÄTTMASKIN | ELC | ELCENTRAL/MEDIASKÅP | | |
| TT | TORKTUMLARE | PLATS FÖR TV | | | |
| | BÄNKSKIVA MED ÖVERSKÅP | | INFÄLLD SPOTLIGHT | | |
| | SPISHÄLL | | SPEGELBELYSNING PÅ VÄGG | | |

RUMSHÖJD CA 2,50 m, OM INGET ANNAT ANGES.

FÖNSTER ÅR GLASADE NER TILL GOLV OM INGEN BRÖSTNINGSHÖJD ANGES.

